

only single products it seemed of interest to examine *trans*-1,2-diphenyl-1-propene. We have found only one product, 1,2-diphenyl-1-chloromercuripropanol-2, by hydroxymercuration in 1,2-dimethoxyethane. Methoxymercuration gives only 1,2-diphenyl-1-chloromercuri-2-methoxypropane. These structures have been defined by hydrazine hydrate reduction to 1,2-diphenylpropanol-2 and 1,2-diphenyl-2-methoxypropane.

Experimental²

1,2-Diphenyl-1-chloromercuripropanol-2.—To a suspension of 3.0 g. (0.0155 mole) of *trans*- α -methylstilbene³ (m.p. 80.5–81.5°, diffraction [20] 4.88; [16] 6.96, 6.48; [12] 4.52, 3.86; [10] 4.68; [8] 3.79; [6] 3.71; [4] 11.78, 3.25; [2] 5.86; [1] 7.52, 4.35, 4.02) and 9.6 g. (0.031 mole) of mercuric acetate in 125 ml. of 50% aqueous 1,2-dimethoxyethane was added 1.00 g. (0.004 mole) of benzoyl peroxide. After 6 days agitation at 20–25° the system was filtered into 200 ml. of 3% aqueous sodium chloride. The precipitate was filtered off, washed with methanol (50 ml.) and ether (50 ml.), 1.85 g. (28%), m.p. 131–134°. Crystallization from acetone (15 ml./g.) raised the m.p. to 133.5–135.0°.

Anal. Calcd. for C₁₅H₁₅ClHgO: Hg, 45.0. Found: Hg, 44.4.

1,2-Diphenyl-1-chloromercuri-2-methoxypropane.—To a solution of 6.00 g. (0.031 mole) of α -methylstilbene and 19.1 g. (0.06 mole) of mercuric acetate in 200 ml. of anhydrous methanol was added 1.85 g. (0.0076 mole) of benzoyl peroxide. After 7 days agitation at 20–25° the system was filtered into 350 ml. of 4% aqueous sodium chloride. The precipitate was filtered off and washed with 100 ml. of diethyl ether, 7.8 g. (74%), m.p. 81.5–82.5°. Crystallization from absolute ethanol (8 ml./g.) raised the m.p. to 84.3–85.0°. Diffraction is [20] 8.93; [16] 12.27, 3.18; [14] 7.82, 6.96; [10] 4.16; [8] 6.06, 4.79; [4] 4.44, 4.11, 3.82; [2] 4.37, 3.52, 2.94, 2.79, 2.73, 2.66, 2.45, 2.33, 2.23, 2.17; [1] 3.66, 3.42, 2.54, 2.26.

Anal. Calcd. for C₁₆H₁₇ClHgO: Hg, 43.5. Found: Hg, 43.0.

The etherous extract contained 0.80 g. of unchanged α -methylstilbene.

1,2-Diphenylpropanol-2.—To a solution of 1.45 g. (0.0033 mole) of 1,2-diphenyl-1-chloromercuripropanol-2 in 10 ml. of methanol was added a solution of 1.27 g. (0.0066 mole) of sodium hydroxide in 2.0 ml. of water, then 2.00 ml. (0.035 mole) of 85% hydrazine hydrate. After 7 hours reflux, the system was filtered to remove 0.62 g. (95%) of mercury. The filtrate was diluted with 60 ml. of water and extracted with a total of 30 ml. of diethyl ether. A colorless oil (0.58 g.) obtained from this extract was distilled, b.p. 145–148° (3 mm.), 0.42 g. (60%), m.p. 49.5–51.0°. Mixture melting point with authentic 1,2-diphenylpropanol-2 was not lowered.

A mixture melting point with the alcohol prepared according to the method of Hell⁴ was not lowered. We have never been able to reproduce the melting point of 71–72° quoted by Tuot and Guyard.⁵

1,2-Diphenyl-2-methoxypropane.—To 9.2 g. (0.02 mole) of 1,2-diphenyl-1-chloromercuri-2-methoxypropane in 40 ml. of methanol was added a solution of 1.60 g. (0.004 mole) of sodium hydroxide in 4 ml. of water, then 2.9 ml. (0.05 mole) of 85% aqueous hydrazine hydrate. After 450 minutes reflux the system was filtered to remove 3.65 g. (91%) of mercury. The filtrate was diluted to 150 ml. with water and extracted with a total of 140 ml. of ether. Evaporation of this extract left an oil which was distilled, b.p. 110–112° (13 mm.), 1.33 g. (29%).

Anal. Calcd. for C₁₆H₁₈O: C, 83.9; H, 8.04. Found: C, 83.9; H, 8.50.

When this ether (1.13 g., 0.005 mole) was heated at 70–75° for 150 minutes with 3.3 ml. (0.025 mole) of 47% hydro-

(2) Melting points have been corrected against reliable standards. X-Ray diffraction patterns are expressed at d spacings in Å. with relative intensities [I/I₁] using CuK α radiation.

(3) C. F. Koelsch and R. V. White, *J. Org. Chem.*, **6**, 602 (1941).

(4) C. Hell, *Ber.*, **37**, 453 (1904).

(5) M. Tuot and M. Guyard, *Bull. soc. chim. France*, 1086 (1947).

bromic acid in 6.5 ml. of glacial acetic acid, a yield of 0.90 g. (90%) of 1,2-diphenylpropanol-2, m.p. 50.5–51.5°, was obtained. A mixture melting point was not lowered.

DEPARTMENT OF CHEMISTRY
UNIVERSITY OF TORONTO
TORONTO, ONTARIO

Action of 9-Diazofluorene on ω -Nitrostyrenes and its Substituted Derivatives

BY AHMED MUSTAFA AND ABDEL HAMID ELSAYED
HARHASH

RECEIVED OCTOBER 13, 1953

Recently, Parham and Bleasdale¹ have shown that the condensation of nitroolefins (I) which contain no hydrogen atom alpha to the nitro group with diazomethane results in the formation of products (presumably nitropyrazolines (II)) which yield 3,4-disubstituted pyrazoles (III) in good yields when treated with mineral acids or heat. In two cases the intermediate nitropyrazolines were obtained as crystalline solids. When diazomethane was allowed to react with ω -nitrostyrene (Ia) at room temperature, a quantitative yield of additive product was obtained. However, the product appeared to be polymeric and had no properties commensurate with those of the expected nitropyrazolines (II).

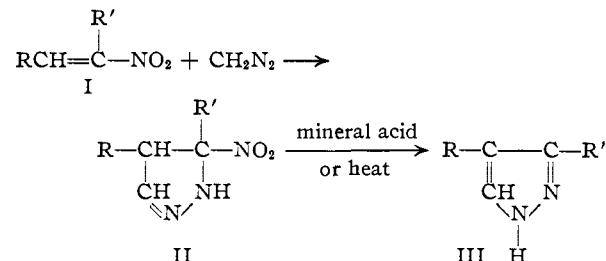

We have now investigated the action of 9-diazofluorene on the ω -nitrostyrenes (Ia–Ie) listed in Table I and found that they react to give the cyclopropane derivatives V listed in Table II, believed to be formed by way of the intermediate pyrazoline, e.g., IV.²

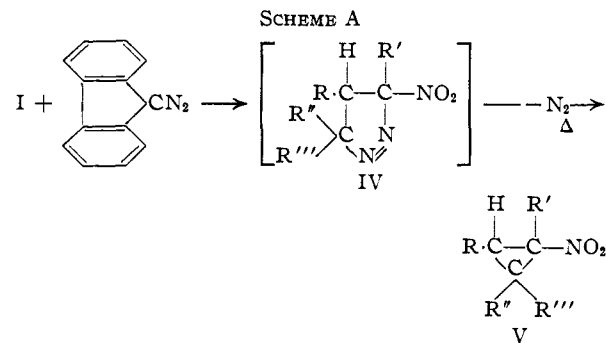

TABLE I

Ia, R = C₆H₅, R' = H; b, R = C₆H₄NO₂-o, R' = H; c, R = C₆H₄NO₂-m, R' = H; d, R = C₆H₄NO₂-p, R' = H; e, R = 3-pyrenyl (C₁₆H₉), R' = H

(1) W. E. Parham and J. L. Bleasdale, *THIS JOURNAL*, **72**, 3843 (1950); **73**, 4664 (1951).

(2) The reaction of 9-diazofluorene with acrylonitrile and methyl vinyl ketone leads directly to the formation of cyclopropane derivatives. Cf. L. Horner and E. Lingnau, *Ann.*, **673**, 30 (1951).

TABLE II

Va, R = C₆H₅, R' = H, R'' and R''' = 9-fluorenylidene (C₁₃H₉)
 b, R = C₆H₄NO₂, R' = H, R'' and R''' = C₁₃H₉
 c, R = C₆H₄NO₂-*m*, R' = H, R'' and R''' = C₁₃H₉
 d, R = C₆H₄NO₂-*p*, R' = H, R'' and R''' = C₁₃H₉
 e, R = C₆H₅, R' = H, R'' and R''' = C₁₃H₉

hydroxide solution (ca. 35%) giving yellow solution in the case of Va and Ve, brown in the case of Vb, orange in the case of Vc and violet in the case of Vd. In general, they are soluble in hot benzene or chloroform, but are sparingly soluble in cold ethyl alcohol and light petroleum ether (b.p. 40–60°).

A solution of 1 g. of each of 3,4-methylenedioxy-B-nitro-

TABLE III

I	V	Time of reactn., hr.	M.p., °C.	Yield, %	Solvent for cryst. ^f	Formula	Carbon, %		Hydrogen, %		Nitrogen, %	
							Calcd.	Found	Calcd.	Found	Calcd.	Found
Ia ^a	Va	10	172	81	A	C ₂₁ H ₁₅ NO ₂ ^g	80.5	80.4	4.8	4.8	4.5	4.4
Ib ^b	Vb	8	191–192	76	B	C ₂₁ H ₁₄ N ₂ O ₄	70.4	70.4	3.9	3.7	7.8	7.6
Ic ^c	Vc	8	180	71	B	C ₂₁ H ₁₄ N ₂ O ₄	70.4	70.2	3.9	3.8	7.8	7.7
Id ^d	Vd	6	193	78	B or C	C ₂₁ H ₁₄ N ₂ O ₄	70.4	70.3	3.9	3.9	7.8	7.7
Ie ^e	Ve	12 and kept 4 days at room temp.	151	56	B	C ₂₁ H ₁₉ NO ₂ ^h	85.1	85.0	4.3	4.1	3.2	3.2

^a "Organic Syntheses," Coll. Vol. I, John Wiley and Sons, Inc., 1932, p. 405. ^b J. Thiele, *Ber.*, **32**, 1294 (1899). ^c K. H. Slotta and G. Szyszka, *ibid.*, **68**, 189 (1935). ^d Van der Lee, *Rec. trav. chim.*, **44**, 1809 (1924). ^e It was obtained after the method described for the preparation of nitrostyrene, in deep orange crystals from benzene or glacial acetic acid, m.p. 188–189° (red melt). *Anal.* Calcd. for C₁₈H₁₁NO₂: C, 79.1; H, 4.0. Found: C, 79.1; H, 3.9. E. Bograchov (*THIS JOURNAL*, **66**, 1612 (1944)) gave m.p. 177° for the same substance. ^f A, benzene and light petroleum (b.p. 40–60°); B, benzene; C, xylene. ^g Mol. wt., 313; found: mol. wt. (Rast), 308. ^h Calcd. mol. wt., 437; mol. wt. (Rast), 431.

The cyclopropane derivatives V (listed in Table II) are colorless and soluble in hot alcoholic potassium hydroxide. The molecular weight of Va is in agreement with the calculated value. When Va is heated to 270° it decomposes to give Δ^{9,9'}-bifluorene (VI)³ and an unidentified resin (probably the polymer of Ia).

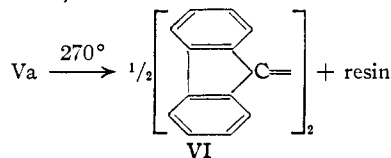

3,4-Methylenedioxy-B-nitrostyrene (I, R = 3,4-CH₂O:C₆H₃; R' = H) and 6-nitro-3,4-methylenedioxy-B-nitrostyrene (I, R = 3,4-CH₂O:C₆H₂NO₂⁶; R' = H) are stable or almost stable toward the action of 9-diazofluorene under the given experimental conditions. Similarly, Ia and Ic are recovered essentially unchanged when treated with a benzene solution of diphenyldiazomethane.

Experimental

General Procedure.—To a solution of 1 g. of Ia in 30 ml. of dry benzene, was added 1.5 g. of 9-diazofluorene⁴ in 20 ml. of dry benzene. The reaction mixture was then refluxed, whereupon the deep red color faded. The reaction products (Va–Ve) were processed as follows (cf. Table III).

The crystals that separated on cooling the reaction mixture in the case of Va, Vb and Vd, were collected and recrystallized. Concentration of the benzene mother liquors gave further crops of the reaction product.

The benzene was evaporated and the oily residue, that remained in the case of Vc, was washed several times with cold light petroleum ether (b.p. 40–60°). The solid that formed was separated and recrystallized.

The mixture of the yellow and orange crystals that separated on cooling the benzene reaction mixture in the case of Ve was filtered off and the yellow crystals were separated mechanically and recrystallized.

The 2-aryl-3-nitrospiro-(cyclopropane-1,9'-fluorene) (Va–Ve) listed in Table II were similarly prepared. They give green color with concentrated sulfuric acid; Ve gives a bluish-green color. They are almost insoluble in hot aqueous potassium hydroxide, but soluble in alcoholic potassium

styrene⁵ and 6-nitro-3,4-methylenedioxy-B-nitrostyrene⁶ in 20 ml. of dry benzene was treated with 1.5 g. of 9-diazofluorene in 20 ml. of benzene. The reaction mixture was refluxed for 12 hours. On cooling, starting nitroolefin was recovered essentially unchanged.

Thermal Decomposition of Va.—Va (0.5 g.) was heated for one hour at 270–280° (bath temp.) in a test-tube shaped vessel (Pyrex glass) which was connected during pyrolysis to a working oil vacuum pump. The reaction vessel was then allowed to cool in a vacuum. The bottom of the reaction vessel contained a brownish-red residue which was extracted several times with boiling ether. After concentration of the ethereal extract to about one ml., light petroleum (b.p. 40–60°) was added dropwise at room temperature till turbidity occurred. A reddish-brown substance separated which was dissolved in a very small amount of hot benzene. After adding a saturated solution of picric acid and keeping aside overnight, orange crystals separated, which proved to be the picrate of VI.

Diphenyldiazomethane and Ia.—One gram of Ia in 20 ml. of dry benzene was treated with diphenyldiazomethane⁶ (prepared from 1.5 g. of benzophenone hydrazone and 3 g. of yellow mercuric oxide suspended in 30 ml. of dry benzene). The mixture was refluxed for three hours, during which the deep color faded. The benzene solution was evaporated and the solid residue was washed several times with cold ether (ca. 25 ml.). The insoluble product was identified as starting material; diphenylketazine⁶ was isolated from the ether solution.

The above experiment was repeated and the reaction mixture was allowed to stand at room temperature for 72 hours in the presence of 0.5 ml. of methyl alcohol. On working out the reaction mixture as above, Ia and diphenylketazine were isolated.

Similarly, Ic was recovered essentially unchanged when treated with diphenyldiazomethane as described in the case of Ia.

(5) H. Burten and J. A. Duffield, *ibid.*, **78** (1949).

(6) H. Staudinger and A. Gaule, *Ber.*, **49**, 1897 (1916).

DEPARTMENT OF CHEMISTRY
 FACULTY OF SCIENCE
 THE CAIRO UNIVERSITY
 CAIRO, EGYPT

Serotonin Analogs. The Synthesis of 5-Dimethylaminoindoles

By ELLIOTT SHAW

RECEIVED OCTOBER 12, 1953

Derivatives of 5-aminoindole have been prepared¹ and shown to be effective antagonists of the

(1) E. Shaw and D. W. Woolley, *THIS JOURNAL*, **75**, 1877 (1953).

(3) Cf. the decomposition of 7,8-9',9'-fluorenyleneacenaphthene at 280° into VI and acenaphthylene (A. Schönberg, A. Mustafa and N. Latif, *THIS JOURNAL*, **75**, 2267 (1953)).

(4) A. Schönberg, W. Awad and N. Latif, *J. Chem. Soc.*, 1368 (1951).